

Temporary Campground Facts & Guidelines

1. Properly Maintained

- a. The licensee of a campground must properly maintain the campground, buildings, sites, and facilities in a clean and sanitary manner as follows:
 - i. Prevent and abate any nuisances in the campground.
 - ii. Maintain vehicular access, as appropriate, throughout the campground area at all times the campground is in use.
 - iii. Campground roads and walkways shall be maintained to provide all-weather access and dust control.
 - iv. Ensure at least one adult who is responsible for campground operations is available at all times the campground is being used.
 - v. Limit and control the number of patrons and vehicles in a campground to avoid overcrowding and to maintain separation distances.
 - vi. Ensure the campground is properly drained and kept free of trash and debris.
 - vii. Implement insect and rodent control measures whenever an insect or rodent nuisance exists.
 - viii. Reasonably control noxious plants such as poison ivy, poison sumac, and other plants which could constitute a hazard to patrons in public use areas.
 - ix. Require the registration of all pets that are permitted within the campground.
 - x. Promptly report to the local health commissioner where the campground is located of any case(s) of domestic or wild animal bites inflicted upon any person in the campground area.

2. Site Requirements

- a. Individual camp sites shall have a minimum area of 1,000 square feet with clearly defined site boundaries.
- b. Each site may have no more than:
 - i. One recreational vehicle and portable camping units. OR
 - ii. Three tents/ portable units.
- c. Each site shall be designed to have separate access that is not through or over an adjacent site.
- d. Properly drained and kept free of trash and debris.
- e. Maintained free of sewage and gray water nuisances.
- f. Each site shall be clearly marked to be readily identifiable and easily readable from the campground road. Each site shall be identified in numerals, letters, or combination thereof in sequential order of at least two inches in size and mounted at least six inches above the ground.

3. Spacing Requirements

- a. At least 15 feet between the side of any recreational vehicle and the side of any other recreational vehicle or portable camping unit located on an adjacent site.
 - i. "A portable camping unit" means dependent recreational vehicles and tents and portable sleeping equipment and similar camping equipment used for travel, recreation, vacation, or business purposes and does not include a manufactured home or mobile home.
- b. At least 10 feet distance between the ends of any recreational vehicle and any other recreational vehicle and/or portable camping units located on an adjacent site.

- c. At least five feet between all units on the same site.
- d. At least 10 feet between portable camping units located on adjacent sites.
- e. At least 15 feet distance between camping unit and any building, public roadway, street, alley, and or any right of way designated for vehicular traffic.
- f. At least seven and one-half feet distance between camping unit and campground property line.

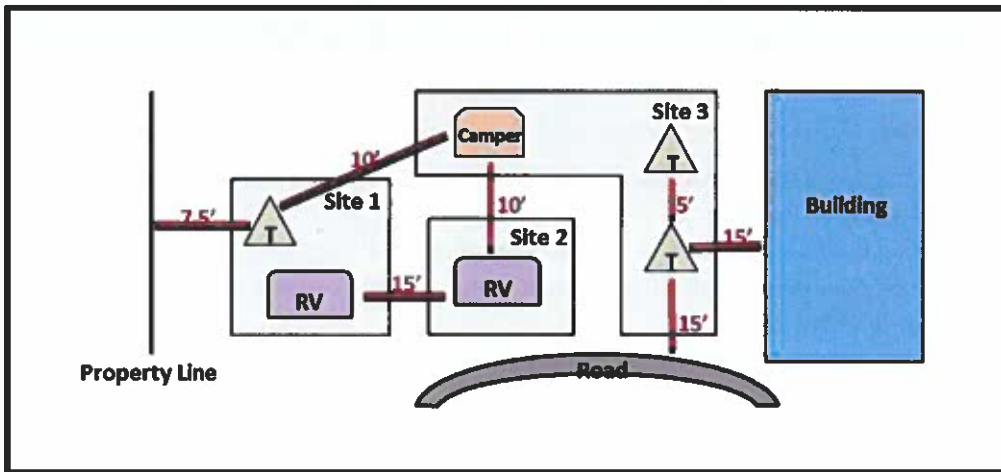

4. Water Supply Requirements

- a. A water supply for human consumption is not required at a campground. However, when such a water supply is provided, it must be of adequate quantity and shall be from:
 - i. A public water system, or a system owned and operated by the campground licensee, which meets the requirements of Ohio Revised Code 6109 and the rules adopted thereof.
 - ii. Private water system which meets the requirements of Ohio Revised Code 3701.44. A current copy of the last water sample taken must be submitted for review.
- b. Water used for flushing of holding tanks may be from a supply that does not meet the requirements of Ohio Administrative Code 3701-26-05(D)(2)(a) only if all outlets from the supply are clearly and indelibly labeled to the effect that the water is “unsafe for human consumption.”
- c. All water hoses used for human consumption must be rated for potable water use only.

5. Sewerage System Requirements

- a. All sewerage systems shall meet the standards of Ohio Revised Code Sections 6111 or 3718.
- b. Where a public or private water supply system provides service to individual sites in a temporary campground, a sewerage disposal plan must be approved by the Ohio Environmental Protection Agency or the local health department, depending on which has jurisdiction, prior to the submittal of plans to the local health department.
- c. When the services of a septic hauler are used for the ultimate disposal of sewage pumped from holding tanks, a service agreement must be kept on file by the temporary campground operator on the premises, including information regarding where the waste will be disposed, the dates of any service and the amount of any waste removed from the premises. All septage haulers shall be registered in accordance with requirements.
- d. A licensee may haul domestic septage from individual holding tanks of recreational vehicles and portable camping units on site and within the campground. The domestic septage must only be hauled within the campground in an approved manner. No domestic septage may be hauled on public roadways.
- e. Temporary campground licensees must provide adequate methods for disposing wastes from camping units which may include but are not limited to:
 - i. On-site dump stations.
 - ii. The services of a septage hauler that is registered by a local health department; or
 - iii. Individual site connections to a sewerage system.

6. Gray Water Recycling Systems

- a. Located so that no camp site is farther than 200 feet in walking distance and there should not be less than 12 sites for one system.
- b. Easily accessible and provided with a sign indicating the facility is for gray water only and no sewage is permitted.
- c. Shall provide adequate methods for disposal of gray water from camping units which may include but are not limited to:
 - i. On-site gray water recycling systems which comply with the requirements of Ohio Administrative Code (E)(1); or
 - ii. Disposal by the services of a septage hauler. A written service agreement shall be kept on file on premise, including information regarding where the waste will be disposed, the dates of any service, and the amount of any waste removed from the premises.

7. Shower Requirements, if provided

- a. Separate shower facilities for non-family groups must be provided for each sex. If showers for each sex are in the same building, they must be separated by solid walls or partitions extending from the floor to the ceiling. A coved base at the juncture of the walls and floors is required. Shower building entrances and exits must be provided with self-closing doors or modesty shields.
- b. The floors must have an easily cleanable, non-skid finish, impervious to moisture, and self-draining.
- c. The interiors of these facilities must be illuminated by artificial lighting.

8. Toilet Facilities

- a. Located so that no site is farther than 1,000 feet walking distance from every camp site.
- b. Provided for men and women. Each facility or room shall be plainly designated. If a family facility is provided it must be counted as one unit in the total required minimum.
- c. Properly maintained and provided with adequate toilet tissue at each toilet fixture.
- d. Provided with self-closing doors or modesty shields at the entrance and exits.
- e. Provided in accordance with minimum schedule below:

CAMP SITES	MEN-URINALS	MEN-TOILETS	WOMEN-TOILETS
5-15	0	1	1
16-30	1	1	2
31-60	1	2	3
61-90	2	2	4
91-120	2	3	5
121-150	3	3	6
151-200	4	4	8
201-300	5	5	10
301-400	6	6	12
401-500	7	7	14
501+	Add 1 per 200	Add 1 per 200	Add 2 per 200

9. Solid Waste

- a. The storage and collection of solid wastes must avoid the creation of health hazards, rodent harborages, insect breeding areas, and accidents.
- b. Containers must be durable, watertight, non-absorbent, and easily cleanable and must have tight fitting covers.
- c. Containers must be sufficient in number and size to accommodate all solid waste between collections. Containers must be easily accessible and emptied weekly unless otherwise authorized by licenser.
- d. Open burning for campfires:
 - i. May be allowed if approved by local fire authority, AND;

ii. The following conditions are met:

1. Used with clean seasoned firewood, natural gas or equivalent, or any clean burning fuel with emissions that are equivalent to or lower than those created from the burning of seasoned firewood.
2. Not used for waste disposal purposes.
3. Have a total fuel area of 3 feet or less in diameter and 2 feet or less in height.

10. Safety

- a. Firefighting equipment of the type and quantity acceptable to the state fire marshal or local fire department must be available for use in fighting fires.
- b. A sign identifying an emergency telephone, or identifying the location of the nearest telephone, must be posted in the campground. The sign must contain the address of the campground and telephone numbers for emergency services, including but not limited to police, sheriff, and fire or rescue unit.
- c. First aid equipment consisting of unused disposable gloves and a sufficient supply of materials to stop bleeding, to clean and cover minor cuts and abrasions must be accessible in the campground.
- d. Rules established for the campground must be conspicuously posted or provided to patrons. Rules must include, but are not limited to, the following general areas:
 - i. Traffic control.
 - ii. Overcrowding and spacing of camping units.
 - iii. Noise control.
 - iv. Use of hazardous materials and fire safety.
- e. Licensee must maintain a record of all injuries occurring within the campground area that require attention of medical personnel.
- f. Licensee must ensure no motorized vehicles are used in such a manner in the campground that a hazard to life or safety occurs.
- g. All playground equipment must be installed and maintained in a safe condition.
- h. Water and other recreation areas under the control of the licensee must be operated and maintained in a safe condition.

11. Electrical Requirements

- a. All electrical work within a campground must adhere to the current edition of the National Electrical Code (NEC) or the local code, whichever is more stringent, with written certification by a licensed contractor.
- b. Whenever electrical service is available to the campground, all public service buildings must be provided with external lighting sufficient to provide illumination and visibility.

Plan Review

Items to be submitted to the local health department:

1. A copy of the completed Site Evaluation Form (HEA 5228).
2. Signed application and license fee payment.
3. Written verification from the local or township fire department having authority where the camp is located that adequate fire protection can be provided.
4. Written septage hauler service agreement, if applicable.
5. Written safety plan including not limited to:
 - a. Unlicensed electric/motorized vehicles.
 - i. No alcohol consumption during operation.
 - ii. Operated in safe manner.
 - iii. No operation on or across road or highway.
6. A vicinity map including the following information:
 - a. The total area and dimensions (in square feet) of the park.
 - b. Maximum density of the park-camp (total number of camping units).
 - c. The location of each site with its number.
 - d. The location of all roadways and walkways.
 - e. The location of permanent buildings, gathering tents, etc.
 - f. The location of all sanitary facilities (restrooms or showers).
 - g. The location of all clean water facilities.
 - h. The location of all wastewater disposal sites.
 - i. The location of all solid waste collection sites.
 - j. The location of all area lighting and electrical systems.

Plan Review Questions

- 1) How will pets be registered (please attach a form if used)?
- 2) What is the size of each site in square feet?
- 3) Explain how each site will be clearly marked so that it is readily identifiable and easily readable from the road.
- 4) Explain how you will monitor distances between units to ensure required distances are being met.
- 5) Will a water supply for human consumption be provided? YES NO

If yes, what water supply is the water from:

City water (please name _____).

Private water (please provide a copy of most current water sample results for review).

Services of private water hauler (submit service agreement with registered water hauler).

- 6) What method will be used to dispose of sewage from camping units?

On-site dump stations.

Services of septage hauler (submit service agreement with registered septage hauler).

Individual site connections to a sewerage system (submit process and where it will be dumped).

- 7) Are gray water recycling systems located within 200 feet of each camp site? YES NO

- 8) What method will be used to dispose of gray water.

On-site gray water recycling system.

Services of septage hauler (submit service agreement with registered septage hauler).

Other, please specify.

9) Will shower facilities be provided? YES NO

a. If yes, what company will provide the showers?

10) Are toilet facilities located within 1,000 feet of each site? YES NO

11) Complete the table.

# of CAMP SITES	# of MEN-URINALS	# of MEN-TOILETS	# of WOMEN-TOILETS

12) What company will provide the restrooms?

13) How will solid waste be stored throughout the campground?

14) Will the containers be durable, watertight, and non-absorbent with tight fitting doors/lids?

YES NO

15) How many solid waste containers will be provided?

16) What company will collect and dispose of the solid waste properly?

17) Where is the sign identifying the emergency phone posted in the campground?

18) Where is the first aid kit located within the campground?

19) How will your rules be distributed to the public?

Conspicuously posted. Name location:

A copy provided to each patron.

20) Are there any permanent buildings or temporary tent structures located on the campground?

YES NO

a. If yes, please explain the use for the buildings and structures.

21) Will the licensee provide any of the following for its patrons?

Food given away for free with no required donation.

Temporary Permit through local health department.

Mobile Units. Please name:

No food will be available from licensee.

22) Who should be contacted with any questions in regard to this packet or to set up inspections?

a. Name:

Phone Number:

Frequently Asked Questions

What is a temporary campground?

It is any tract of land used for a period not to exceed 21 days per calendar year for the purpose of parking five or more recreational vehicles, dependent recreational vehicles or portable camping units or any combination thereof, for one or more periods of time that do not exceed seven consecutive days or parts thereof.

When do I need to apply for a temporary campground permit through the Local Health Department?

The operator of a temporary campground shall apply for a license and approval at least 15-days prior to the event date. This will allow the local health department to review the application, generate the license, and complete inspections. If we do not receive the application and fee at least 15-days prior to the event, your application may be declined. Operating a temporary campground without a license is a violation of Ohio law and the local health department may take appropriate legal action.

What do I need to submit for approval?

1. Signed application and payment.
2. A copy of the Site Evaluation Form (HEA 5228) that has been completed by the local health district. A request for a site evaluation can be made to your local health district to complete this form for submission.
3. The completed information as outlined in the “Plan Review” section above.

What happens after submittal of temporary plan review packet & all additional paperwork?

The local health department may request additional information and return incomplete plans to the applicant. Once the plans are approved, an inspection will be scheduled. The local health department will complete one site inspection prior to issuing a license to make sure that the temporary campground setup is consistent with the approved plans.

Do I need a food permit?

Your temporary campground license does not authorize you to prepare and serve food for a charge or required donation. A temporary food license from your local health department is required. All food prepared, served, and/or sold at the temporary campground must be from an approved and licensed food service operation – and this includes prepackaged foods. Please call the local health department if you have any questions.

What do I do if I need to ask for a variance or waiver from the requirements?

Submit a written request for a variance or waiver at least 90 days prior to the event with supporting documentation to the Director of the Ohio Department of Health. Please call the local health department if you have any questions.

This packet is designed to be a guide highlighting many important considerations for operating a temporary park-camp campground. However, the information contained within this packet does not contain all of the applicable rules for camps. This packet is a short summary of the Ohio Administrative Code Chapter 3701-26. This code is available online at www.odh.ohio.gov. We suggest you review these rules. You are responsible for complying with all rules found in this chapter. You are also responsible for training your support staff/volunteers to comply with these codes. The information provided does not, and is not intended to, constitute legal advice; instead, all information is for general informational purposes only.

Revised: 2/2024

Temporary Campground Application for Plan Review and License to Operate

Name of Temporary Campground			Health District HIGHLAND COUNTY HEALTH DEPT.		
Address of event			<p align="center">Directions: (please print)</p> <ol style="list-style-type: none"> Complete one application for each temporary campground event; Sign and Date the application; Include the required items for review per OAC 3701-26-05(C)(10) License will not be issued until plan review is approved. Contact Local Health District to obtain the license fee amount. 		
City/Zip					
Start date	End date	# of days for this event (≤7 days)			
Name of Owner / Licensee					
Address					
City/ State /Zip					
Phone #		E-mail			
Number of sites proposed		Water Supply <input type="checkbox"/> Public PWS <input type="checkbox"/> Private <input type="checkbox"/> N/A PWS name:		Type of Sewerage System <input type="checkbox"/> Municipal <input type="checkbox"/> Dump Station(s) <input type="checkbox"/> Septage Hauler <input type="checkbox"/> On-site <input type="checkbox"/> N/A <input type="checkbox"/> Other:	
Fires permitted on campsites? <input type="checkbox"/> Yes <input type="checkbox"/> No		Local Fire District			

Person to Contact regarding inspections, maintenance, or emergencies, if different from licensee.

Name	Phone #	E-mail
------	---------	--------

I hereby certify that I am the licensee, or the authorized representative of the establishment listed above, and agree to abide by the rules that apply for this license. I certify that the information provided is a true and accurate statement of the facts.

Signature	Date
-----------	------

Check or money order for the license fee, payable to:

Return the fee and application to:

<i>(Licensor to complete: either pre-printed, or with a label or stamp)</i>	Health District HIGHLAND COUNTY HEALTH DEPT.	
	Street address 1487 N. HIGH ST. SUITE 400	
	City HILLSBORO	
	Zip 45133	Phone # 937-393-1941

LOCAL LICENSING AUTHORITY TO COMPLETE BELOW

Date Plan Review Application Rec'd:	Date Plan Review Approved:	Number of Days Licensed this Year (including this event):
Plan Review Approved by:	Number of sites approved:	License Fee: \$ 2024= \$46.00+.50 per site over 50 sites

Application approved for license as according to the applicable sections of the Ohio Revised Code

Processor:	Date payment received:	Date Processed:
License Audit No.	Health District License No.	

Each plan submittal shall include the following prior to the start of the plan review per OAC 3701-26-05(C)(10):

1. Signed Temporary Campground Application for Plan Review and License to Operate Form HEA 5336;
2. Site Evaluation Report, ODH HEA 5228 completed and signed by the licensor (local health district);
3. Written verification by the fire protection authority that has jurisdiction in the area that adequate fire protection can be provided to the campground;
4. **Two sets of drawings * to include:**
 - a. Layout of temporary campground;
 - b. Plot plan showing location, number, and size of sites;
 - c. Internal access or camp roads;
 - d. Detail of water supply (if provided);
 - e. Detail of sewerage system;
 - f. Detail of water and sewer hookup at individual sites (if applicable);
 - g. Method and layout of electrical distribution system including individual service connections;
 - h. Location of shower facilities (when provided);
 - i. Location, number, and type of toilet facilities;
 - j. Location, number, and details of gray water recycling system;
 - k. Location, number, and details of dump station(s);
 - l. Variance or waiver requests (if needed) must be received by the Ohio Department of Health (ODH) for review at least 90 days prior to the event.

Temporary Campground applications are to be submitted for review to the local health district having jurisdiction.

***Reproductions from other documents are acceptable if legible. Drawings should be scale.**

Note - the applicant assumes responsibility for obtaining any permits that may apply to the construction and/or development of this temporary campground.

Ohio Department of Health SITE EVALUATION REPORT

To be completed by licensor having jurisdiction.

Authority: Ohio Administrative Code Chapter, 3701-26-03

TYPE OF PROJECT	
<input type="checkbox"/>	Recreation Camp (RC)
<input type="checkbox"/>	Recreational Vehicle Park (RVP)
<input type="checkbox"/>	Combined Park Camp (CPC)
<input checked="" type="checkbox"/>	*Temporary Campground (TPC)

*TPCs are the responsibility of the local health district.

TYPE OF DEVELOPMENT	
<input checked="" type="checkbox"/>	New
<input type="checkbox"/>	Substantial Alteration

COUNTY HIGHLAND		LOCAL HEALTH DISTRICT HIGHLAND COUNTY HEALTH DEPARTMENT 937-393-1941	
FACILITY NAME X		OWNER X	
STREET ADDRESS X		STREET ADDRESS X	
CITY, ZIP CODE X		CITY, STATE, ZIP X	
FACILITY PHONE NO. X	FACILITY E-MAIL X	OWNER PHONE NO. X	OWNER E-MAIL X

I. Site Information/Conditions:

A. Describe access thoroughfares on and adjoining the site: _____

B. Describe adjoining land uses: _____

C. Describe significant topographic features such as unusable land area, sharp changes in grade, waterways, or wetlands: _____

D. You may use the back of this form for additional remarks or to sketch the above or any other appropriate items.

E. Soil classification: list predominant soil types and characteristics (refer to the "Soil Conservation Service, Soil Survey", _____)

F. Research and comment on previous land uses to include, but not limited to, landfills or hazardous substance/disposal sites: _____

<p>II. Lot information:</p> <p>Number of existing, fully developed lots: _____ (any lot a man. home can be placed/occupied)</p> <p>Total number of proposed lots: X _____</p>	<p>III. Describe work proposed:</p> <p>X _____</p> <p>_____</p> <p>_____</p>
--	---

IV. Utilities (check appropriate items):

A. Transmission lines:	Existing	Proposed	No Indication	
Electric	<input type="checkbox"/>	<input type="checkbox"/>	<input type="checkbox"/>	
Gas, propane, fuel oil	<input type="checkbox"/>	<input type="checkbox"/>	<input type="checkbox"/>	
Water	<input type="checkbox"/>	<input type="checkbox"/>	<input type="checkbox"/>	
Sanitary Sewer	<input type="checkbox"/>	<input type="checkbox"/>	<input type="checkbox"/>	
Storm sewer	<input type="checkbox"/>	<input type="checkbox"/>	<input type="checkbox"/>	
B. Service systems:				Public Private Other
Water	<input type="checkbox"/>	<input type="checkbox"/>	<input type="checkbox"/>	<input type="checkbox"/> _____
Sanitary	<input type="checkbox"/>	<input type="checkbox"/>	<input type="checkbox"/>	<input type="checkbox"/> _____
Campgrounds only:				
Restroom(s)	<input type="checkbox"/>	<input type="checkbox"/>	<input type="checkbox"/>	
Dump station(s)	<input type="checkbox"/>	<input type="checkbox"/>	<input type="checkbox"/>	
Waste water drain(s)	<input type="checkbox"/>	<input type="checkbox"/>	<input type="checkbox"/>	

Based on soil types in Sec. I E above, do you oppose use of a leaching type waste water drain(s)? Yes No

Note: New development or expansion may be subject to OEPA review and permits.

V. Expansion/Substantial Alteration/New Development:

A. Is the proposed development licensed by the licensor? Yes No

1. Verify the number of lots on the license permit with section II above, and with previously approved plans, plan approval letters, and plan extension approval letters.

B. Comment on the compliance of the existing facilities to the appropriate rules. _____

C. Objections to development of the existing or proposed project. _____

SANITARIAN	DATE
------------	------

